

Triangularwave Technologies, Inc.

ULTRA FILTRATION SYSTEM A NEW EVOLUTION IN WATER TREATMENT...

Removes impurities as small as .015 microns from source water

Ultra Filtration System:

Until now, one of the best ways to effectively protect against waterborne contaminants has been Reverse Osmosis. In this day of water shortages and mandated water rationing, Reverse Osmosis is not always a practical and cost effective solution. Ultra-Filtration removes impurities as small as .015 microns from the source water. Now, you can have continuous, crystal clear safe water. It uses very little water during the flush cycle and does not add chemicals to the water.

Ultra Technology:

Inside ultra-filter's pressure vessel is a network of hollow fibers that reduce microbiological contaminants in the water. Ultra-filters multi-bore technology is very effective because there are seven capillaries in every fiber, making the fibers stronger and more efficient. The Ultra-filters inside out filtration process is superior to most hollow fiber products in that concentrated contaminants trapped on the inside surface of the capillary walls are easily removed by high velocity flushing. This inside-out filtration process assures continuous, effective cleaning and assures the longest possible life of the system.

Ultra Meter/Controller:

The meter/ controller, with advanced microprocessor technology, acts as the brain of the Ultra-filtration system. The set-up is quick, easy and control is very accurate. A flush cycle is initiated when a pre-set number of gallons pass through the system. The frequency and duration of the flush setting will be dependent on the quality of the incoming water. The controller will also sense when water has not been used in a 24 hour period and will initiate a brief flush cycle keeping the system fresh while using minimal water. Bright led lights indicate system status.

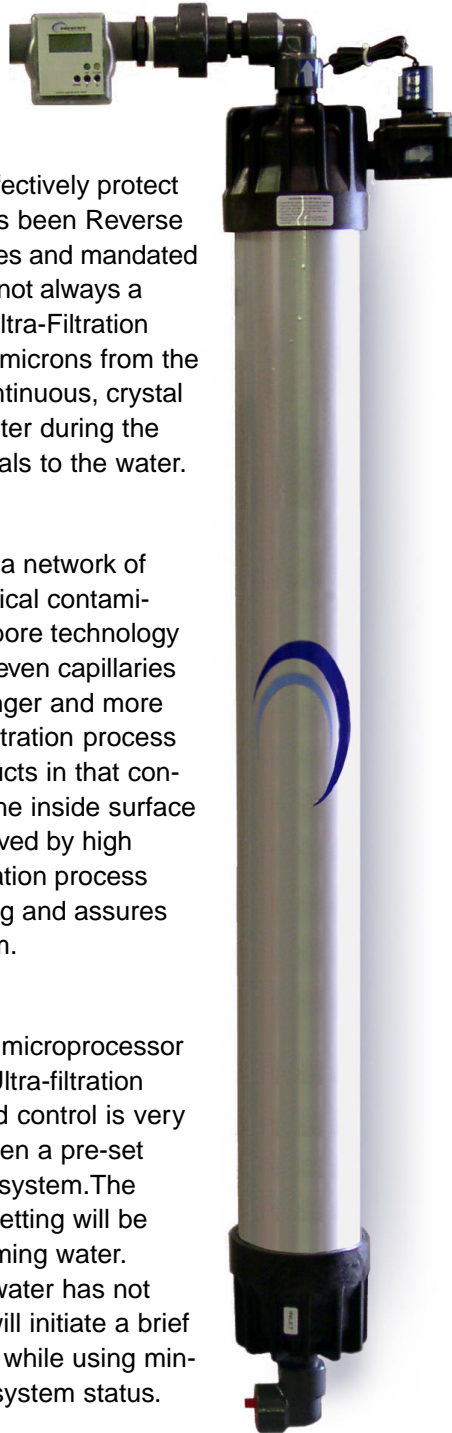

TWT-UFAC11

High Purity at High Flow Rates

Ultra-filter reduces turbidity, cysts, bacteria and some viruses from the source water. Ultra-filter delivers this level of water quality at flow rates up to 10 gpm with very low pressure drop.

Very Little Water Wasted

Ultra filter is very efficient. Ultra filters can use as little as 2 gallons of water per day to flush the module clean.

The Right Kind of Water

While reducing turbidity, harmful cysts and bacteria, ultra filter leaves in any beneficial minerals. It does not reduce TDS, so there are no corrosion of piping, or leaching issues.

Self-Maintaining System

Easy-to-program Meter/Controller determines when to flush the module and how much water to use in the process. It's so smart, it knows when facility water has not been used and initiates a brief flush to keep the module performing at its best.

Meets All Plumbing Codes

With 1" fittings at the inlet and outlet, ultra filter meets all plumbing codes.

This system is ideally suited for Wells, Offices, Factories, Farms, Medical/Dental & Laboratory Environments, Hospitals, Restaurants, Schools, HVAC, Cooling Tower/Condenser, Chillers and anywhere the need for cleaner water to use and drink is required.

SPECIFICATIONS TWT-UFACI I

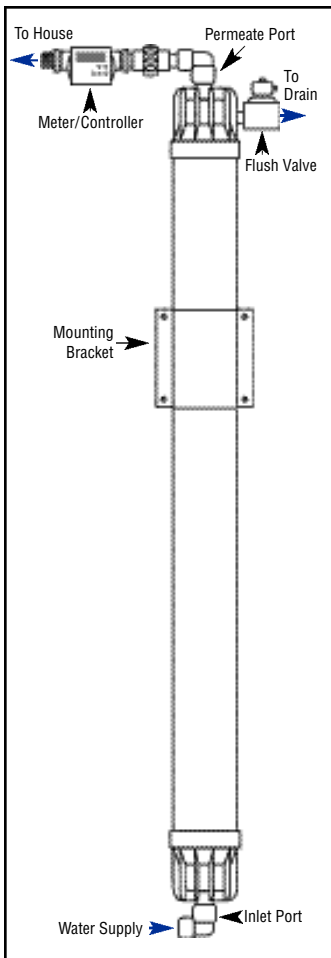

Meter Controller:

The Meter/Controller, with advanced microprocessor technology, acts as the brain of the system. The set-up, is quick, easy and control is very accurate. A flush cycle is initiated when a pre-set number of gallons pass through the system. The frequency and duration of the flush setting will be dependent on the quality of the incoming water. The controller will also sense when water has not been used in a 24 hour period and will initiate a brief flush cycle keeping the system fresh while using minimal water. Bright LED lights indicate system status.

Meter Controller Specifications

Power Supply	110 VAC/12 VDC (50/60 Cycles)
Flush Volume:	
Range	20-1000 Gallons
Increment	20 Gallons
Flush Duration:	
Range	10-100 Seconds
Increment	1 Second
Maximum Flow Rate	10 Gallons per Minute

System Specifications

Maximum Operating Pressure	72 psi (5 Bar)
Maximum Operating Temp.	40 Degree C (104 Degree F)
Max. Trans Membrane Pressure	45 psi (3 Bar)
pH Range	3-10
MWCO	100kD
Membrane Material	Polyethersulfone
Inlet and Outlet Fitting Size	1 inch NPT
Flush Valve Fitting Size	3/4 inch NPT
Shipping Weight	34 lbs.
Operating Weight	51 lbs.

Average Flow Rate at 50 psi:

Gallons per Hour	540
Gallons per Minute	9
Liters per Hour	2045
Liters per Minute	34

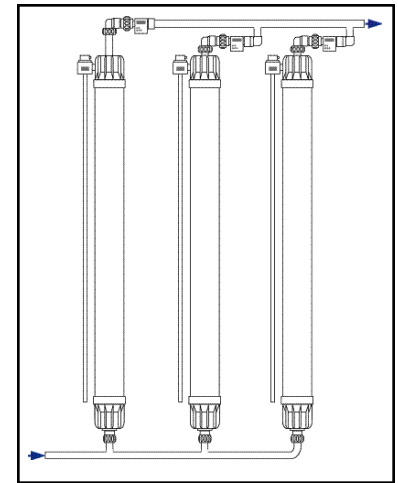

Ultra filtration units may be configured to meet various application and flow requirements

In order to ensure the greatest level of performance and satisfaction in your work with the TWT products & systems, we recommend that you contact our engineering staff, who will be pleased to work closely with you to determine the optimal application and installation for your industry specific needs.

TWT® Patented Deposit Control Technology

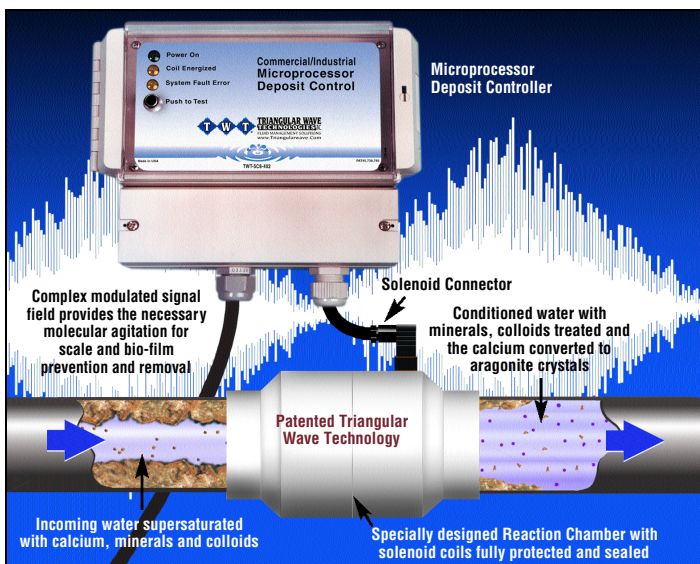

Technologically Advanced Methods for Water & Fluid Management Potable Water, Process and Waste Water Treatment & Conditioning

- Provides the effects of softened water, neutralizes calcium hardness effects in the water
- Removes and prevents scale buildup

- Uses no salts or other chemicals
- Service and maintenance-free
- Improves efficiency of all water-fed equipment and extends its life cycle
- Quickly pays for itself and continues saving
- Descales the entire plumbing system over time
- Designed for safety—the output is safe to both personnel and equipment. There is no electrical contact with the pipe

TWT Deposit Control Systems enhance other treatment technologies as well, including chemicals, ozone, ultraviolet, separators and other filtration systems, keeping them clean and enhancing their operation. In this way, their full treatment benefits are realized, with reduced maintenance requirements. Consider using TWT Deposit Control Systems in conjunction with any fluid treatment systems as a complementary technology.

TWT® Specializing in: All Fluid-Based Industries

- Chemical-Free Deposit Control Systems
- Ultraviolet / Ozone / Disinfection & Purification Systems
- Ionization Purification Systems
- Custom Systems Design & Integration
- Water Filtration Products